

TOP VIEW

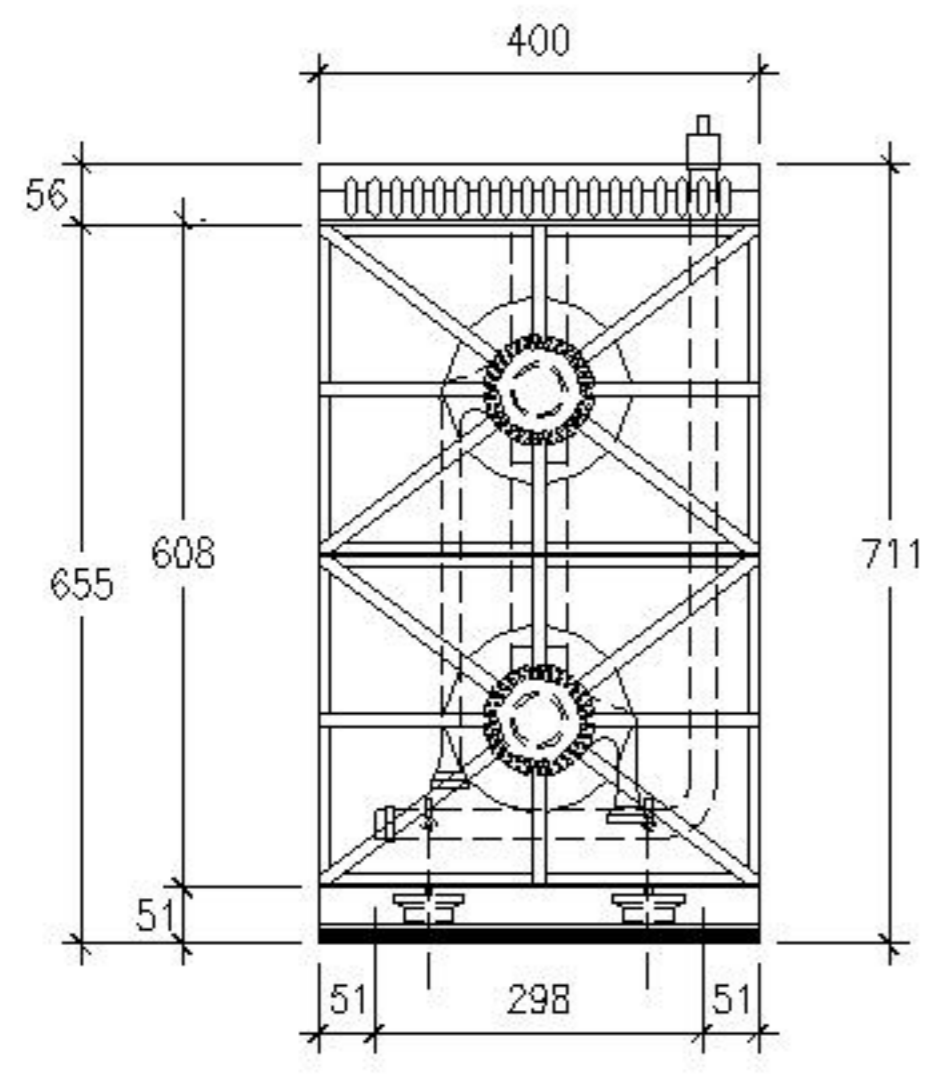

ISOMETRIC

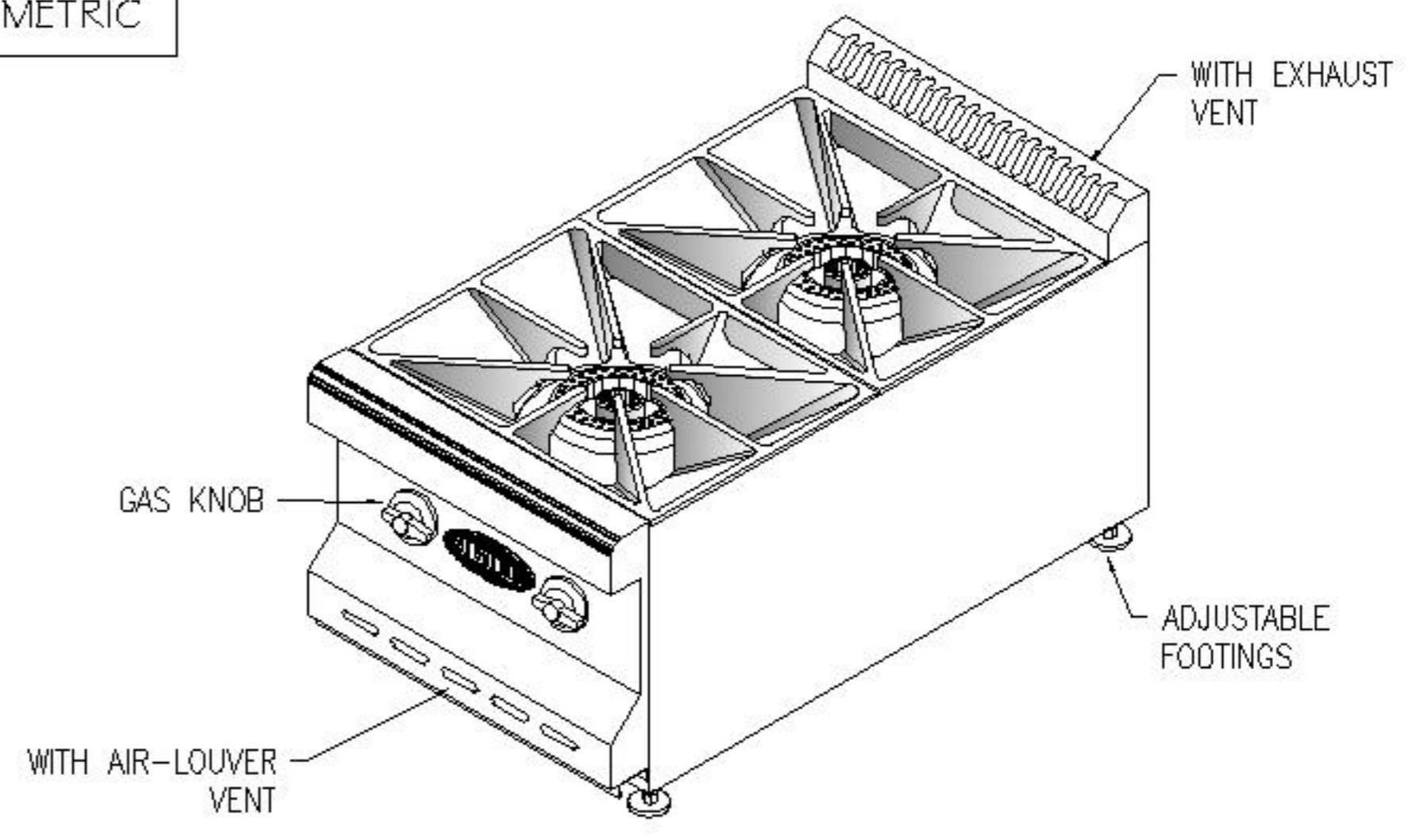

FRONT VIEW

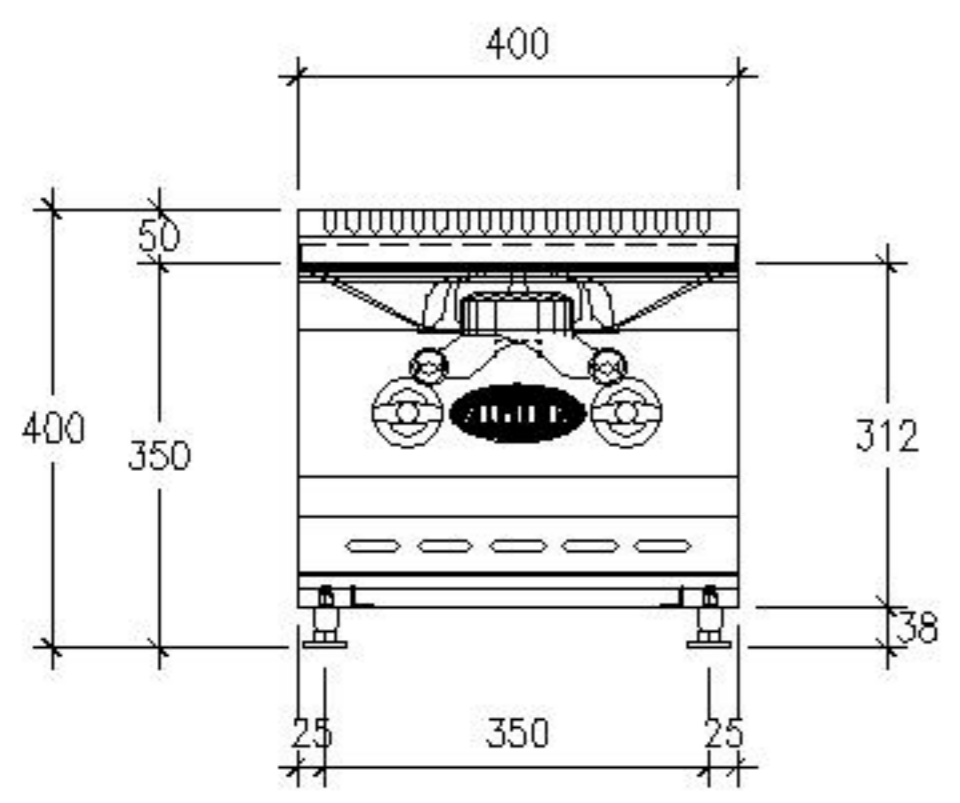

SECTION SIDE VIEW

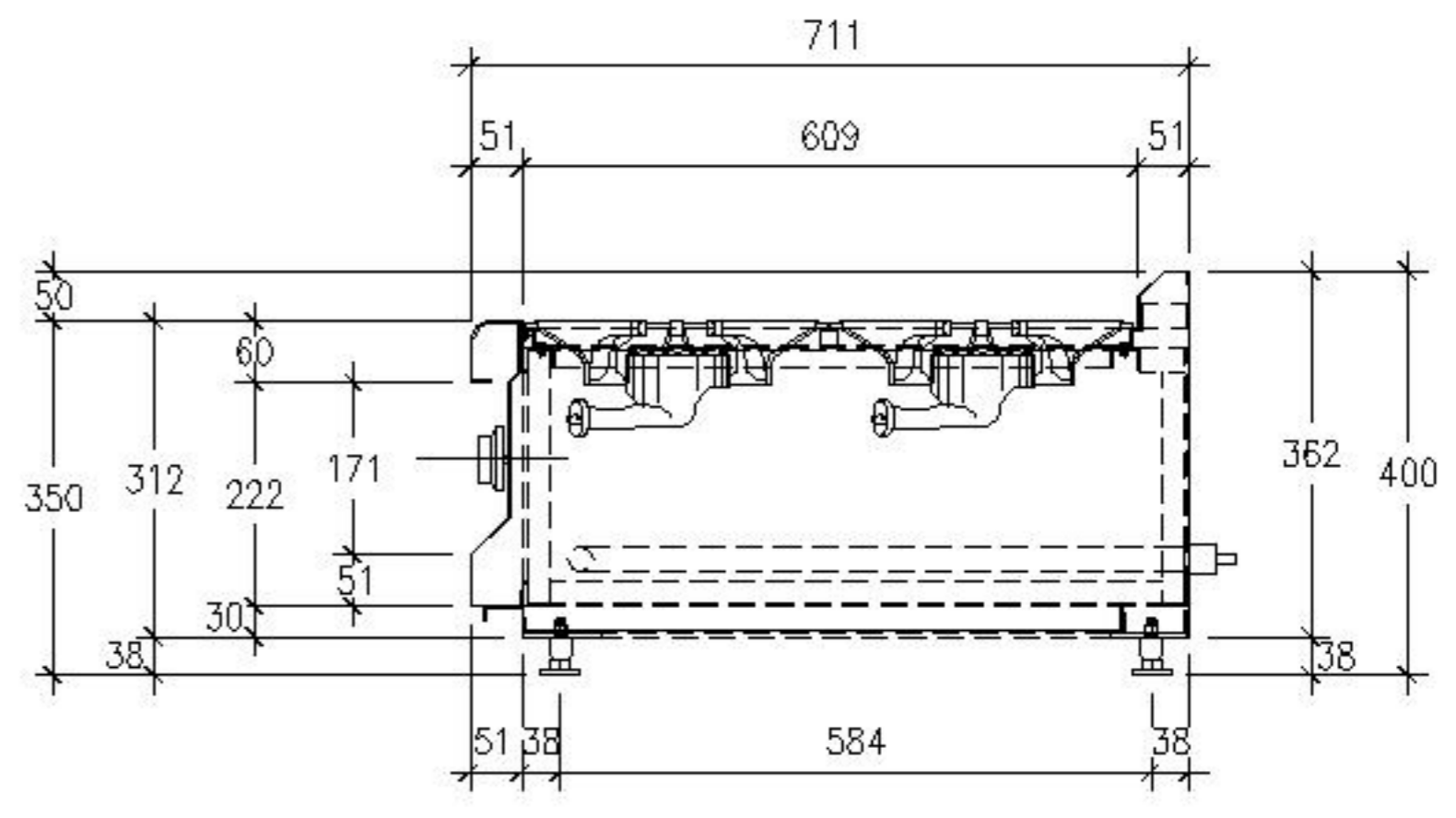

GENERAL SPECIFICATIONS:



| | | |
|-----|-----------------------------------------------|--|
| 1. | 12 GA. S/S ANGLE BASE LEGS | |
| 2. | 16 GA. S/S TOP FRAME MID. SUPPORT | |
| 3. | 16 GA. S/S TOP FRAME & REMOVABLE FRONT NOSING | |
| 4. | 20 GA. S/S LOWER FRONT PANEL | |
| 5. | 20 GA. S/S CONTROL PANEL & SIDE PLATE | |
| 6. | 20 GA. S/S DRIP PAN SLIDES | |
| 7. | 20 GA. S/S BACK PLATE & REMOVABLE BACK SPLASH | |
| 8. | 22 GA. S/S DRIP PAN HANDLE | |
| 9. | 16 GA. GI. BURNER HOLDER | |
| 10. | 22 GA. GI. DRIP PAN PLATE | |
| 11. | 25mm X 25mm x 3mm.THK. M.S. ANGULAR FRAMING | |

GENERAL SPECIFICATIONS:



| | | |
|-----|------------------------------------------------|--|
| 12. | (2) PCS. BIG YOTO BURNER - 27,000 BTU/HR. EACH | |
| 13. | (2) PCS. PILOT BURNER | |
| 14. | (2) PCS. GAS VALVE WITH THERMOCOUPLE | |
| 15. | (2) PCS. HEAVY DUTY GAS KNOB | |
| 16. | (4) PCS. ADJUSTABLE FOOTINGS | |
| 17. | | |
| 18. | | |
| 19. | | |
| 20. | | |
| 21. | | |
| 22. | | |

DRAWING REVIEW

Submission Date: _____

APPROVED

APPROVED SUBJECT TO COMMENTS
RESUBMISSION NOT REQUIRED

NOT APPROVED, RESUBMIT AS NOTED

Approved by: _____

Date returned to contractor: _____

Client's approvals apply to method of construction and material specification only. Contractor is responsible to ensure all dimensions are verified to suit site conditions and fabricated accordingly.

| | | | |
|---------------|--------------------|----------------------------------------|----------------|
| PROJECT | " ASIA FOOD EXPO " | | |
| | (S.J.O: 0072-15) | | |
| ITEM | 1 | 2-OPEN RANGE BURNER (Counter Top) | |
| Project Ref # | - | Date | SEPT. 22, 2015 |
| Designed by | - | Revision | - |
| Drawn by | ACE | Rev. Date | - |
| Verified by | - | Scale | NOT TO SCALE |
| Approved by | - | Quantity | 1 - UNIT |

ALLIED METALS
THE PROFESSIONAL IN FOOD SERVICE EQUIPMENT
2000 ORN. HALL HIGHWAY, MUIZON, SAN JOSE DEL MONTE CITY, CALIFORNIA
TEL. NO.: (408) 520-0811 TEL/FAX NO.: (408) 520-4324
E-mail: www.alliedmetals.com